

ISS	REVISED BY:	REVISION DATE	ECO #

NOTES:

MATERIAL:

BRACKET & BACK STRAP - DUCTILE IRON, 40 KSI YIELD
 SLEEVE - STEEL, 50 KSI YIELD

WELDING REQUIREMENTS:

ALL WELDING TO BE PERFORMED BY WELDERS CERTIFIED UNDER SECTION 5 OF AWS D1.1

FINISH:

HOT DIP GALVANIZED PER ASTM A123
 HOT DIP GALVANIZED PER ASTM A153 (HDW)

DIMENSIONS: INCHES

HARDWARE:

HEX HEAD BOLT, 1/2" X 6 PER ASTM A325 (2 EA)
 HEX HEAD BOLT, 1/2" X 2-1/2" GR.5 PER ASTM A325 (2 EA)
 HEX JAM NUT, 1/2" PER ASTM A563 (4 EA)
 FLAT WASHER 1/2" PER ANSI B27.2 (4 EA)
 BY OTHERS, 5/8" X 5 CONCRETE WEDGE BOLTS PER ESR-2526 (6 EA)

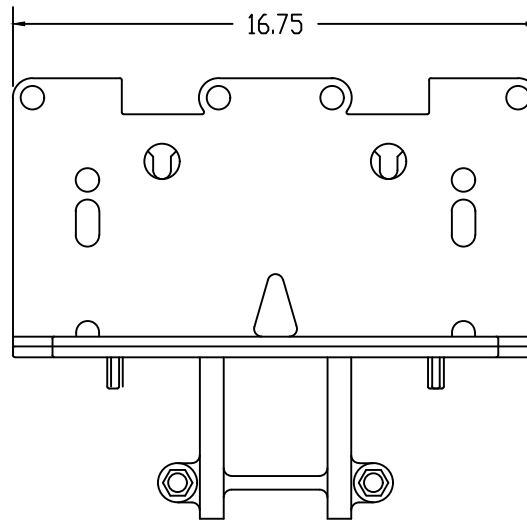
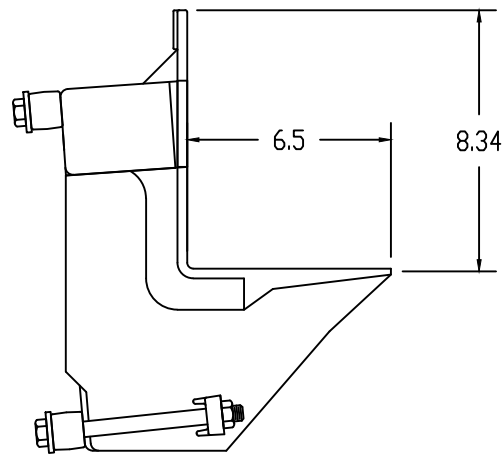
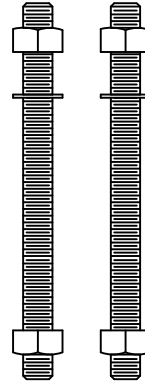
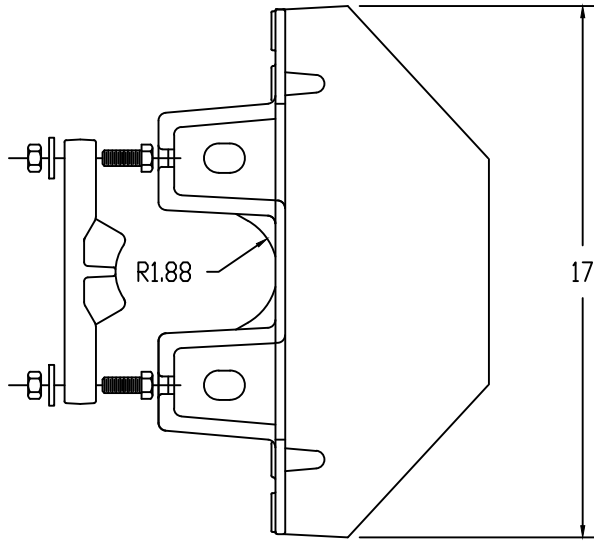

This drawing contains confidential information that is the property of MacLean Power, L.L.C. ("MacLean"). Use of MacLean's confidential information without MacLean's express written consent is strictly prohibited and may expose you to legal liability. If you believe that you received this material in error, please destroy it or return it to MacLean Power, L.L.C., Kingsley Park Five, 481 Munn Rd. Suite 300, Fort Mill, SC 29715, USA.



WWW.MACLEANPOWER.COM

CATALOG NUMBER:			DIXIE350
SHEET NAME:		Sheet1	1 OF 1
DRAWING DESCRIPTION:			
FOUNDATION REPAIR BRACKET NO T-PIPE			
DRAWN BY:	DH	DATE:	08/19/21
APPROVED:			DR