

ISS	REVISED BY:	REVISION DATE	ECO #

NOTES:

MATERIAL:
STEEL, 36 KSI YIELD

WELDING REQUIREMENTS:
ALL WELDING TO BE PERFORMED BY WELDERS CERTIFIED
UNDER SECTION 5 OF AWS D1.1

WELD ALL JOINTS

FINISH:
NONE
HOT DIP GALVANIZED PER ASTM A153 (HDW)

DIMENSIONS: INCHES

HARDWARE:
HEX HEAD BOLT, 3/4" X 5-1/2" PER ASTM A325 (1 EA)
7/8-9UNCX12 L THREAD ROD (2 EA)
HEX JAM NUT, 3/4" PER ASTM A563 (1 EA)

MECHANICAL RATING:
ULTIMATE COMPRESSION RATING - 110 KIPS

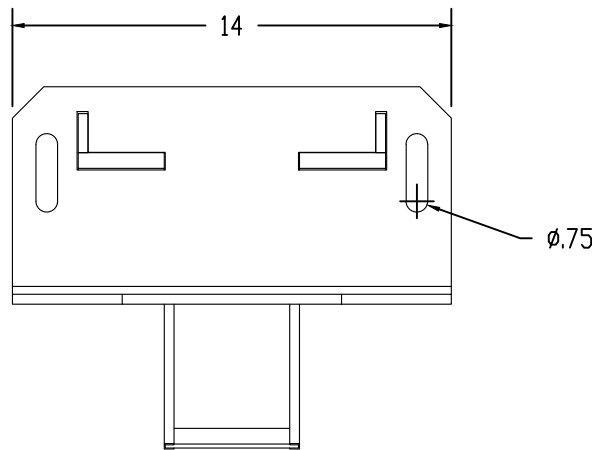
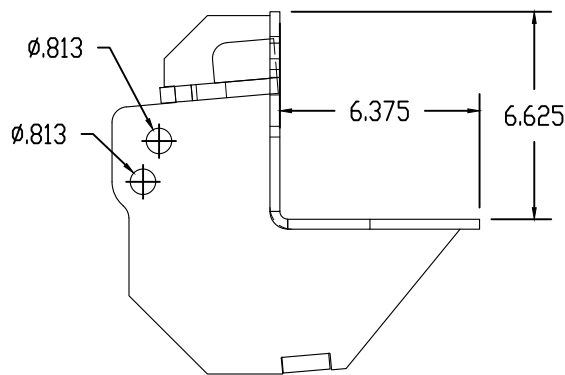
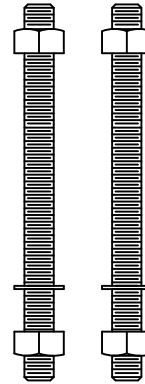
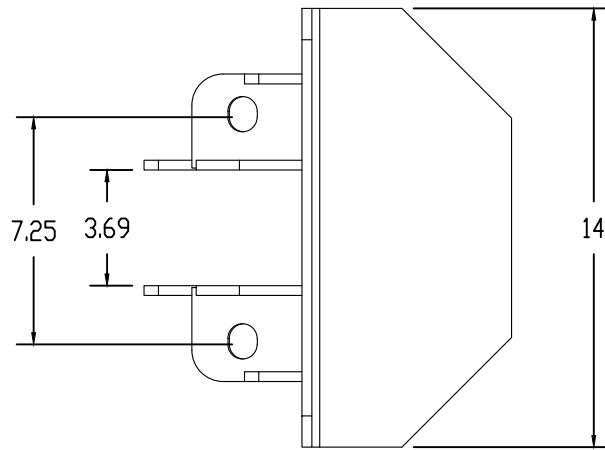

CATALOG NUMBER: DIXIE350FU		
SHEET NAME: Sheet1	1 OF 1	
DRAWING DESCRIPTION: FOUNDATION REPAIR BRACKET UNGALVANIZED, NO T-PIPE		
DRAWN BY: DH	DATE: 10/25/21	APPROVED: DR



WWW.MACLEANPOWER.COM

This drawing contains confidential information that is the property of MacLean Power, L.L.C. ("MacLean"). Use of MacLean's confidential information without MacLean's express written consent is strictly prohibited and may expose you to legal liability. If you believe that you received this material in error, please destroy it or return it to MacLean Power, L.L.C., Kingsley Park Five, 481 Munn Rd. Suite 300, Fort Mill, SC 29715, USA.