

ISS	REVISED BY:	REVISION DATE	ECO #

NOTES:

WELDING REQUIREMENTS:  
ALL WELDING TO BE PERFORMED BY WELDERS CERTIFIED UNDER SECTION 5 OF AWS D1.1

FINISH:  
ITEMS 1 & 2: PAINT, BLACK  
ITEMS 3, 7 & 10: PAINT, RED  
HOT DIP GALVANIZED PER ASTM A153 (HDW)  
YELLOW ZINC DICHROMATE PER ASTM B633 (Gr. 8 HDW)

DIMENSIONS: INCHES

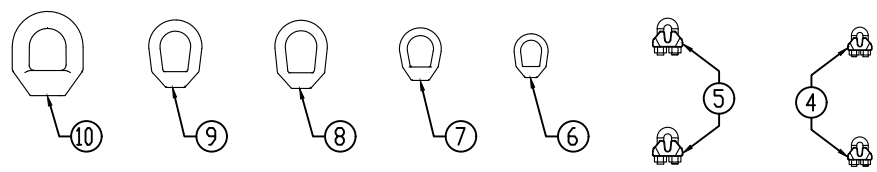
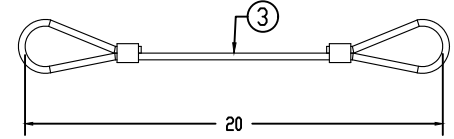
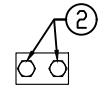
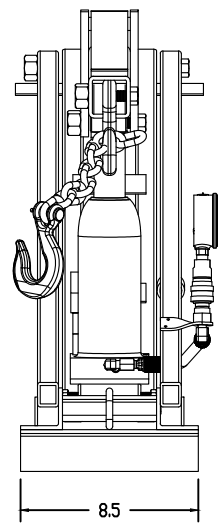
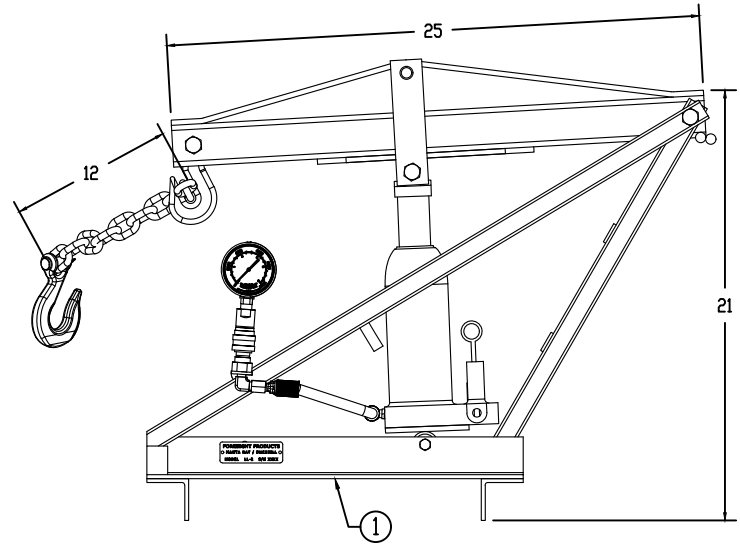

ITEM	PART NO.	CAT. NO.	DESCRIPTION	QTY
1			8,000 LB JACK ASSEMBLY	1
2	P75819	50092	JS-58U JAW SET HEAT TREATED	1
3	P75536	20085	0010G02003 5/16 X 20 SLING	1
4	F830052	10095	WRC-08 WIRE ROPE CLIP 1/4	1
5	F830053	10097	WRC-10 WIRE ROPE CLIP 5/16	1
6	F830776	20834	EN-12G 3/8-16 EYE NUT	1
7	P75507	20014	EN-16 1/2-13 EYE NUT	1
8	F830462	20015	EN-20 5/8-11 EYE NUT	2
9	F830710	20432	EN-22G(NE-20) 11X16-11 EYENUT	2
10	F830735	20618	CTB-EN EYE NUT	1

CATALOG NUMBER: 50172		
SHEET NAME: Sheet1	1 OF 1	
DRAWING DESCRIPTION: LL-2 ANCHOR LOCKING KIT MANUAL JACK - 8,000LBS		
DRAWN BY: DH	DATE: 06/29/21	APPRVD: DR



WWW.MACLEANPOWER.COM

This drawing contains confidential information that is the property of MacLean Power, L.L.C. ("MacLean"). Use of MacLean's confidential information without MacLean's express written consent is strictly prohibited and may expose you to legal liability. If you believe that you received this material in error, please destroy it or return it to MacLean Power, L.L.C., Kingsley Park Five, 481 Munn Rd. Suite 300, Fort Mill, SC 29715, USA.